

- PZ1, PZ2 Continuous tone (RS #273-074)
 PZ3 Pulsed tone (RS #273-066)
 B1 Auto-Reset Breaker, 10A
 S1 Key Switch, 1A
 S2,S4 Momentary Normally-open Switch, 100mA
 S3 Momentary Normally-open Switch, 0.25A
 S5 SPST Toggle Switch, 10A
 P1,J1 16/3 Orange Cord (Cut for connectors)
 P2 AA Battery Pack (or equivalent), 12V
 J2 Igniter Leads with strain relief
 J3 Battery Leads with strain relief
 K1 SPDT Automotive Relay, 30A
 R1,R2 470 Ohm Resistor
 R3,R4 1K Resistor

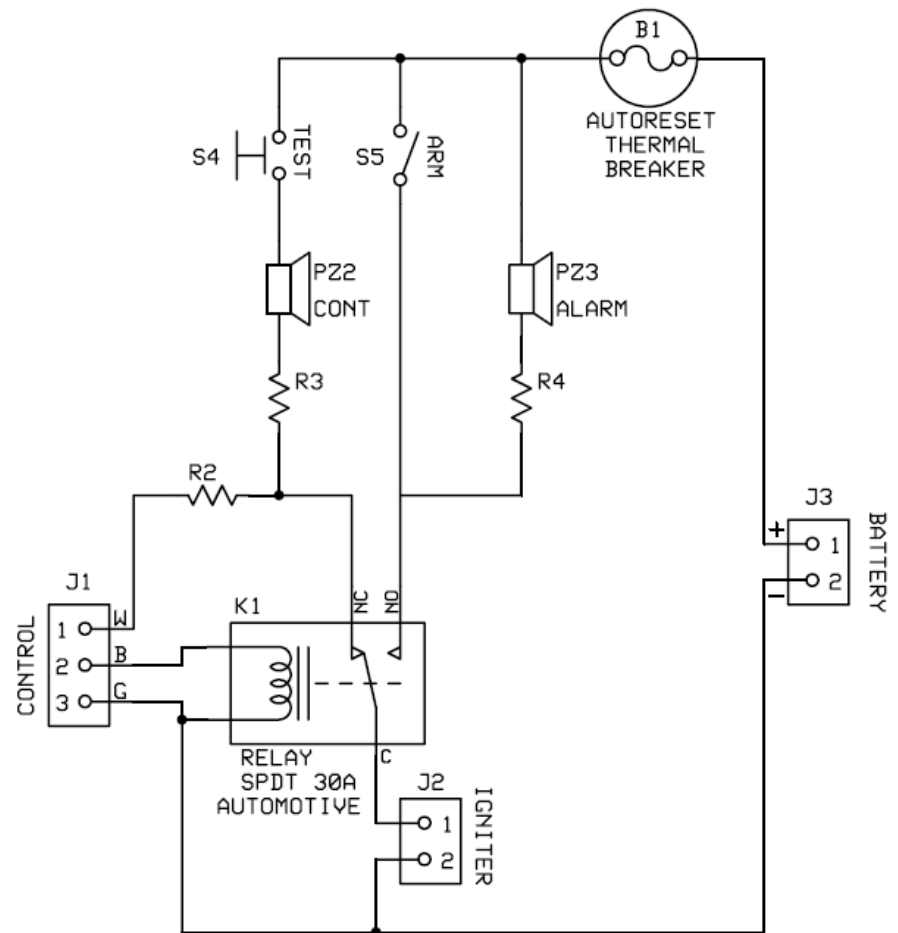

Relay Launch Controller

CONTROL BOX & PAD BOX

John S. DeMar
jsdemar@gmail.com

Rev 1.1
 12/9/2006